



polyvision™
SWITCHABLE LCD PRIVACY GLASS

Privacy at the flick of a switch!

Technical Specification for ESG Polyvision™
Switchable LCD Privacy Glass

Table of Contents

| | | | |
|--|-----------|------------------------------|-----------|
| Overview | 4 | | |
| Principles of Privacy Glass Technology | 4 | | |
| Features & Benefits | 4 | | |
| Benefits to our Customers | 4 | | |
| Applications | 5 | | |
| Technology | 6 | | |
| Technical Data | 7 | | |
| Shapes | 8 | | |
| Electrical | 9 | | |
| Electrical Installation | 9 | | |
| Bus bars | 10 - 11 | | |
| Typical Wiring Diagrams | 12 | | |
| Shipping & Receiving | 13 | | |
| Shipping | 13 | | |
| Storage | 13 | | |
| Unexpected Breakage | 13 | | |
| Glazing - General Notes | 14 | | |
| Surface Conditions | 14 | | |
| Installation | 14 | | |
| Protection | 14 | | |
| Cleaning | 14 | | |
| | | Setting/Glazing | 15 |
| | | Glazing Methods | 15 |
| | | Frame Design | 15 |
| | | Setting Blocks | 15 |
| | | Glass Protection | 15 |
| | | Trouble Shooting | 16 |
| | | Warranties | 16 |
| | | ESG Product Standards | 17 |

ESG POLYVISION™ Overview

Where discretion is vital, ESG Polyvision™ gives you the choice of privacy or the public gaze at the flick of a switch. Normally a diffused white which acts as a screen, this LCD glass can be made transparent simply by passing an electric current through it. With the power off, liquid crystal molecules in the Privacy film are randomly oriented so that incidental light is scattered, making the glass opaque; but when electricity is applied, the liquid crystal molecules line up and, as light passes through it, the Privacy film becomes optically clear.

ESG Polyvision™ is available in custom sizes and shapes, making it an ideal choice for architects and designers when creating working, home, retail and leisure spaces.

In its white state, LCD glass even becomes the perfect backdrop on which to project presentations, without the need for a separate screen.

Principles of Privacy Glass Technology

Development of LCD Film

Obtained license from Kent State University in 1988

Developed reliable formulations and process

Designed its own equipment for production

Commercialized PDLC film in 1990

Commercialized PDLC glass in 1994

Low Haze version in 2004

Product Type

ESG LCD switchable privacy glass

Features & Benefits

Unique Features

- The largest size film on the market - up to 1,800mm x 3,500 mm
- Can be combined with certified ESG fire resistant and security glass products, acoustic and decorative interlayers
- Can be applied to curved services, cut into odd shapes or even hole punched to accommodate specific display applications
- No distraction of shutters. Not susceptible to mechanical failure like powered shutters, curtains or blinds
- Blocks 99% of UV rays
- Low working voltage
- Life expectancy of approximately 10,000 cycles or up to 25 years with due care

Benefits to our Customers:

- Manufactured in UK so full support and back up
- Offer supply and installation service - able to supply turnkey system
- Solutions for a wide variety of applications
- Complex supply and fix electrical systems service
- UK Wide delivery service on ESG's own fleet
- Crating and shipping export service

Applications

• Commercial

Meeting rooms, conference rooms, office partition screens, executive offices, doors, sliding doors, roof lights, tradeshow exhibits and command centres

• Dealerships

Showrooms, meeting rooms, sliding doors and customer areas

• Hotels and Restaurants

Hotel room privacy screen, bathroom / bedroom privacy screen, external windows, doors, conference centre windows & roof-lights, bar & restaurant screens, toilet cubicles, balustrades and balconies

• Projection

Internal or external high resolution rear projection screens

• Residential

Bathroom / Shower enclosure, projection screens, doors, sliding doors, roof lights, ultra-modern residential and commercial blind applications

• Security

Security windows, bullet resistant glass, bank cashier window and automated teller security windows, vision panels, entrance foyer and cell doors and windows

• Entertainment and Showrooms

Rear projection screens, feature screens, special effects panels and vanity screens

• Healthcare

Hospital (nursery, emergency, ICU, operation room), fire resistant doors, hospital and privacy/restriction of view

• Retail

Advertising screens, changing rooms and projection

• Executive Cars

Privacy screens and security solution

• And many more

Technology

Principle:

LCD Privacy Film is made of two layers of transparent conductive film sandwiched with PDLC material. The film is then laminated between two pieces of glass. When electricity is applied to the film the liquid crystals line up and ESG Polyvision™ becomes transparent. When the power is turned off, the liquid crystals return to their normal scattering positions and turn the glass from optically clear to opaque.

The Liquid Crystal Privacy film is encapsulated between layers of glass in a protective laminate construction. ESG Polyvision™ incorporates 5mm low iron tempered glass as standard as this offers considerably higher light transmission. However as ESG manufacture the product in the UK customers can select from a wide range of glass types & colours to suit their project requirements. The outside skins are made up of glass (normally 5 or 6mm annealed glass) each side, then a PVB interlayer is inserted on each side to trap and hold the Liquid Crystal Privacy film.

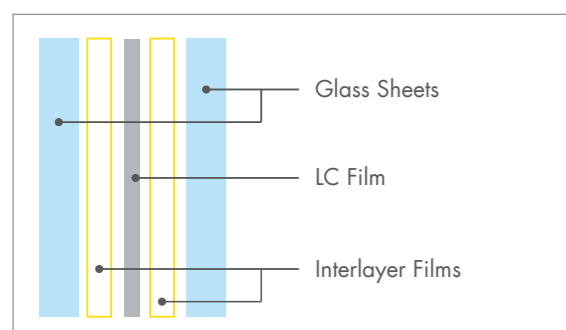

The Liquid Crystal Privacy film is made up from electrically conductive coatings, a polymer matrix and liquid crystals. This film is connected to the power supply via bus bars, electrical wiring and a transformer.

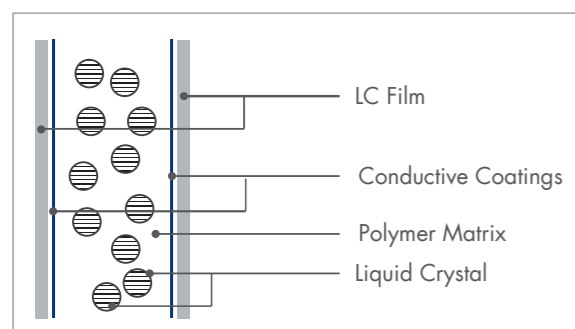

PDLC Light Scattering Mechanism

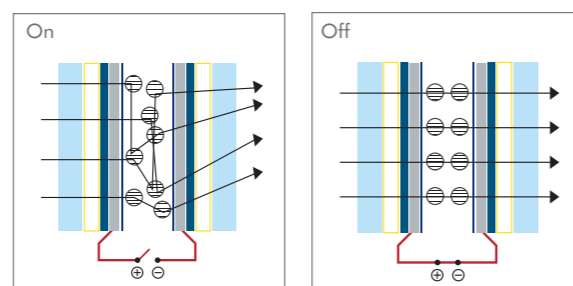

Manufacturing

ESG Polyvision™ is manufactured in the UK by our experienced team and all stages of its production process are monitored and controlled. ESG employ a variety of laminating methods which enables them to produce a wide range of specialist glass products which can incorporate ESG Polyvision™.

This method allows us:

- to control our production process very precisely
- to use different interlayers optimal for specific applications (PVB, EVA, PTU)
- to produce all types of glass: shapes, curved, notches, cut outs, holes, fire glass
- to manufacture special products:
 - ESG Bullet Resistant privacy glass
 - ESG Secure glass
 - ESG Pyrotech™ glass
 - ESG Acoustic glass

We use only the best materials in our production process from major global producers, whose materials are manufactured to internationally recognised quality standards.

Technical Data (ESG Polyvision™ Switchable LCD Privacy Glass)

| | |
|--------------------------|---|
| Glass Colour: | Any colour available (clear, bronze, grey, green tint, blue tint...) |
| Decorative Glass: | Screen printed, sand blasted and patterned |
| Glass Type: | Low iron, annealed, heat strengthened, tempered (All laminated) |
| Thickness: | Various from 10 mm to multi layer laminates |
| Standard Size: | Up to 1,500mm x 3,200mm |
| Bespoke Size: | Up to 1,800mm x 3,500mm |
| | <i>ESG Polyvision™ has the largest sizing on the market</i> |
| Shape: | Any shape, including holes, notches and cut outs |
| Environmental: | <ul style="list-style-type: none"> – Storage -20°C to 70°C (-4°F to 158°F) – Operation -10°C to 70°C (14°F to 140°F) |
| Electrical: | <ul style="list-style-type: none"> – Driving voltage: 65 volts A.C. – Current: 200 mA per square metre – Power: 5 Watts per square metre |
| Switching Time: | Approx. 100 milliseconds at room temperature |
| Warranty: | 5 years |

Example ESG POLYVISION™ Glass Sound Control Data

| Thickness | Standard Construction | ESG Polyvision™ Std dB Rating (Rw) | ESG Polyvision™ Acoustic dB Rating (Rw) |
|-----------|---|------------------------------------|---|
| 10 mm | 4 mm Low Iron tempered glass x 1.52 PVB + 0.4 mm LCD x 4 mm Low Iron tempered glass | 35 | 37 |
| 12 mm | 5 mm Low Iron tempered glass x 1.52 PVB + 0.4 mm LCD x 5 mm Low Iron tempered glass | 36 | 38 |
| 14 mm | 6 mm Low Iron tempered glass x 1.52 PVB + 0.4 mm LCD x 6 mm Low Iron tempered glass | 36 | 39 |

ESG POLYVISION™ - Examples of Optical Performance*

| Thickness | Standard Construction | Visible Light Transmission % (LT) - ON* | Visible Light Transmission % VS Clear Laminated |
|-----------|---|---|---|
| 10 mm | 4 mm Low Iron tempered glass x 1.52 PVB + 0.4 mm LCD x 4 mm Low Iron tempered glass | 80 ** | -12 ** |
| 12 mm | 5 mm Low Iron tempered glass x 1.52 PVB + 0.4 mm LCD x 5 mm Low Iron tempered glass | 79 ** | -11 ** |
| 14 mm | 6 mm Low Iron tempered glass x 1.52 PVB + 0.4 mm LCD x 6 mm Low Iron tempered glass | 78 ** | -10 ** |

* According to manufacturer's test data

** +/- 3%

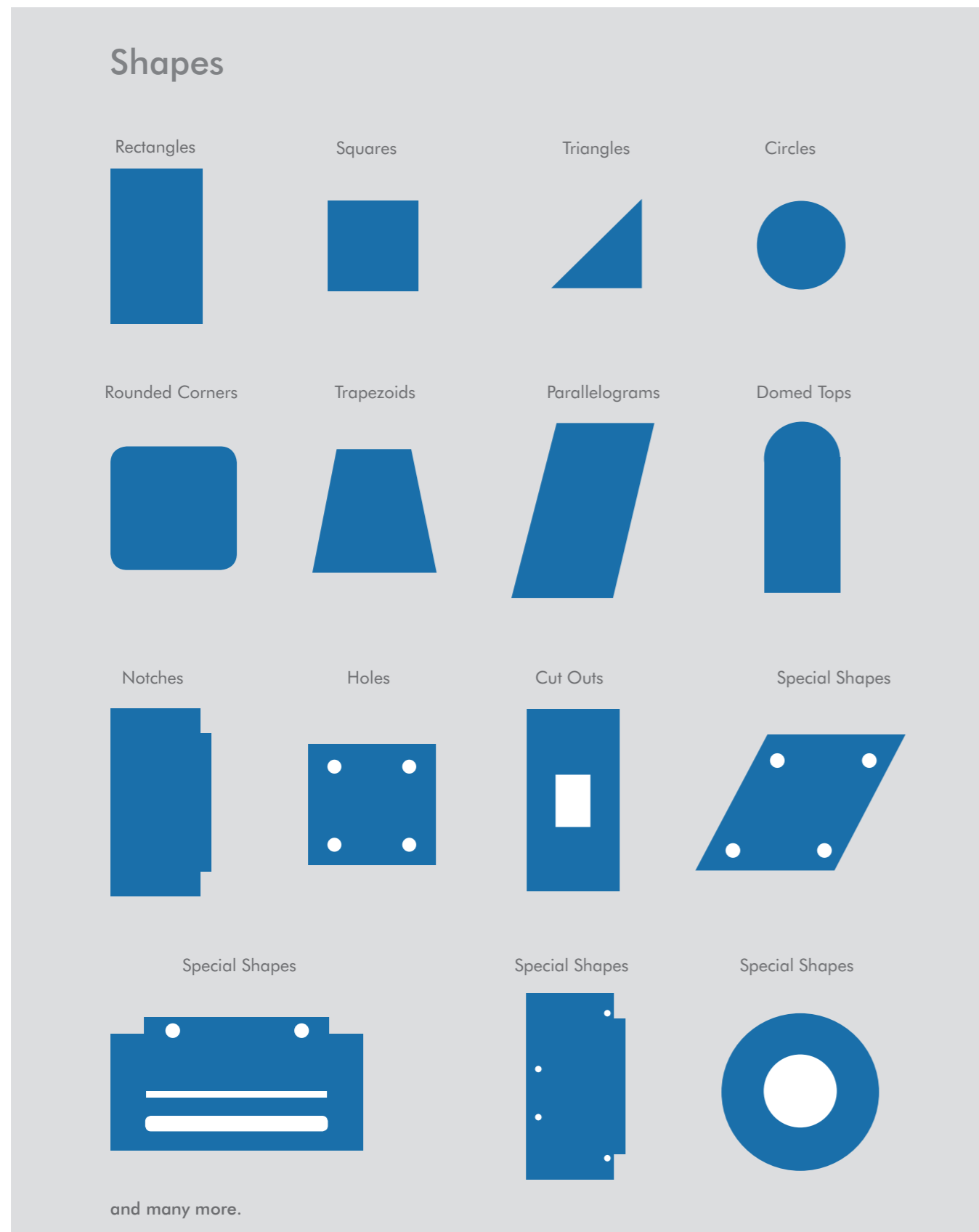

Clear/non switchable areas, very small bubbles and/or visual distortion may be present around notches/holes and cutouts. Therefore customers must allow for coverage of 10mm all around notches/holes & cutouts.

Electrical

As with any electrical device, ESG Polyvision™ must be included in the electrical layout for each project eg position of spurs, switching layout, containment, and connection boxes etc. The installation must meet all local rules and regulations. In addition, any metal frames which could come into contact with the wiring of the panel must be earthed. ESG is not responsible for supplying electrical layout drawings except when they are providing the electrical installation service.

ESG supplied Switches & Controllers – When ESG supply switches, remote controls and/or system control equipment for ESG Polyvision™ installations, staff will demonstrate operation of the switches and controllers to their customer and provide copies of the technical data sheets for the various electrical components in this manual. ESG’s operatives will demonstrate the operation of all such equipment to their client or end user.

It is important to note that the switch/remote control receiver must be wired into the circuit on the mains voltage side of the transformer. Failure to correctly install the switch/remote control receiver will lead to irreparable damage to ESG Polyvision™ panels.

Once glazed ESG Polyvision™ panels must be switched off (into opaque state) for a minimum of six hours each day to reduce the risk of damage to the panel and to extend life expectancy.

Power Transformers

All secondary side 65V supplies will be fused within the transformer to protect the ESG Polyvision™ panels and transformer from fault.

For ease of installation and maintenance ESG supply a number of transformers from 1 x 65V secondary outlet to 6 x 65V secondary outlets as follows :

- 230V AC to 65V 1000ma transformer and enclosure 65va
- 230V AC to 65V with 2x 65V 1000ma transformer and enclosure 130VA
- 230VAC to 65V with 4x 65V 1000ma transformer and enclosure 260VA
- 230VAC 65V with 6x 65V 1000ma transformer and enclosure 390VA

Ensure the transformer input connects to the 230V supply and output to the ESG Polyvision™ panels. Multiple panels should be connected in parallel. Each transformer output is capable of powering up to 4m2.

Fuses - Transformers must be fitted by the electrical contractor in an easily accessible area so that the fuse can be accessed and replaced if necessary. Do not substitute the fuse in the power supply with a higher rated fuse as this may lead to damage to ESG Polyvision™ panels.

Electrical Installation

Electrical Installation by ESG Contractors (UK)

All electrical installations by ESG contractors will be carried out by electrically competent operatives with all relevant qualifications up to BS7671 IEE Wiring Regulations Seventeenth Edition.

The power supply will be calculated to the correct amperage for each project.

All 230V power supplies will use RCBO as a protected device and be calculated to operate within 0.4 of a second under fault conditions.

All transformers will have isolation within a meter.

All secondary side 65V supplies will be fused within the transformer to protect the ESG Polyvision™ panels and transformer from fault.

All installations will be tested to the latest BS7671 IEE Wiring Regulations Seventeenth Edition and on completion the client will be supplied with NICEIC electrical certificate.

Electrical Installation by ESG’s Customer

ESG require all electrical installations of ESG Polyvision™ be completed by a licensed electrician and in compliance with all local rules and regulations.

Before installation the electrician must inspect bus bars, electrode leads and cables to ensure they are properly insulated. No exposed bus bars, electrodes or cables should be allowed to come into contact with metal frames as this may damage the ESG Polyvision™ panels and transformer. Any metal framework into which panels will be installed must be earthed.

Before turning on the power supply the electrician must test the resistance reading between the frame and the electrode to ensure the reading is infinite/open circuit ie there is no connection between the frame and the panels. If the reading is not infinite then the electrician will need to check all bus bars, electrodes and cables until the short circuit is found and insulated accordingly.

Bus bars - Single Laminated or Double Glazed Units

Fig 1. Bus bar on one short edge

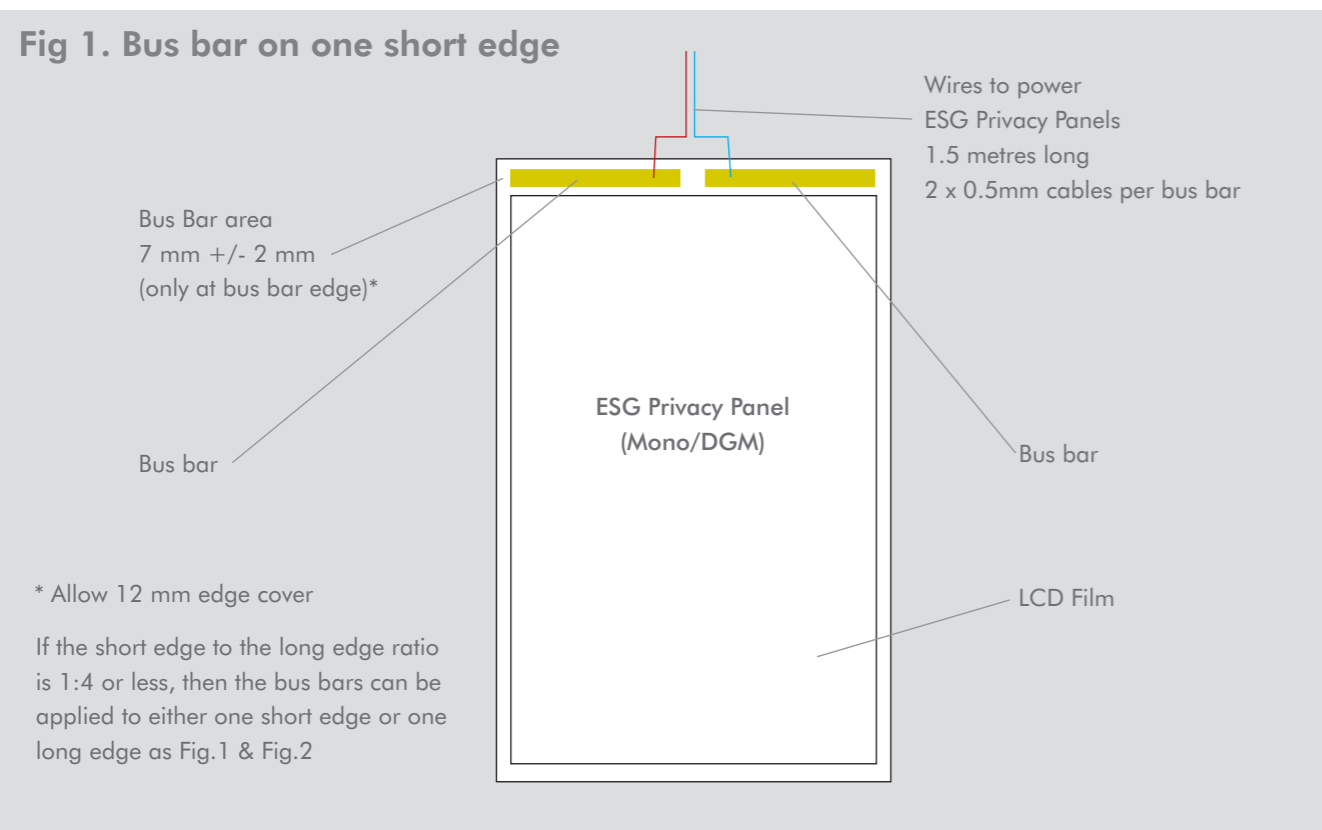

Fig 3. Alternative bus bar solutions – two short edges*

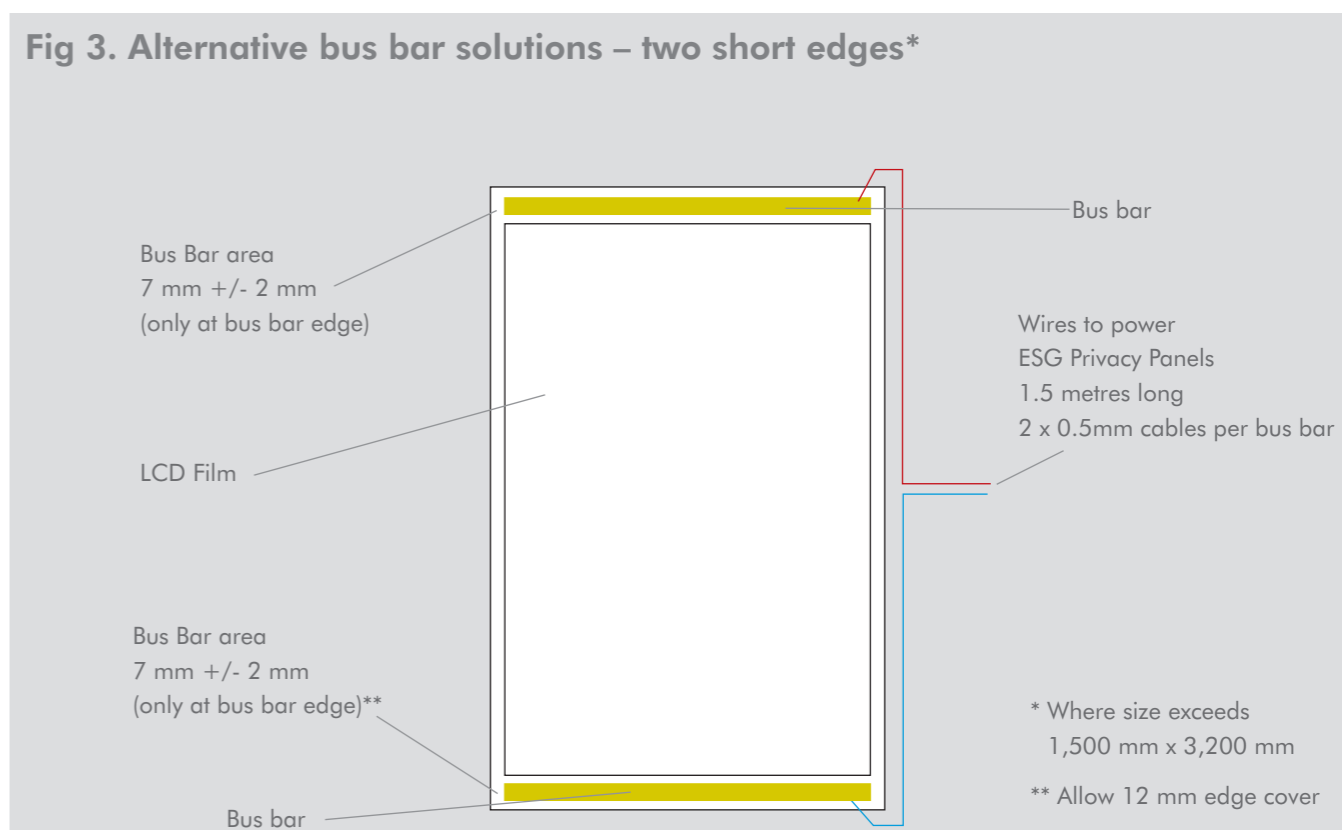

Fig 2. Bus bar on one long edge

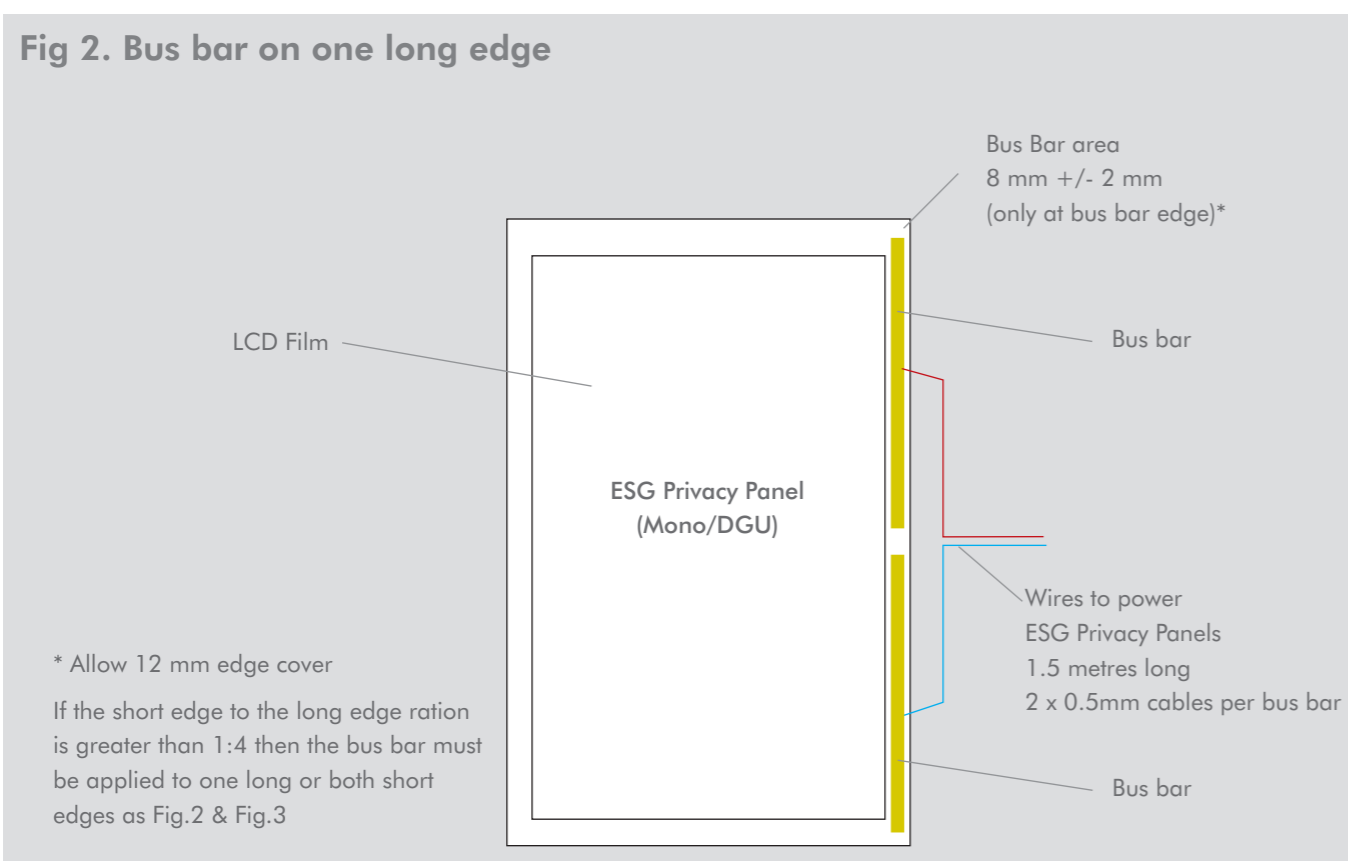
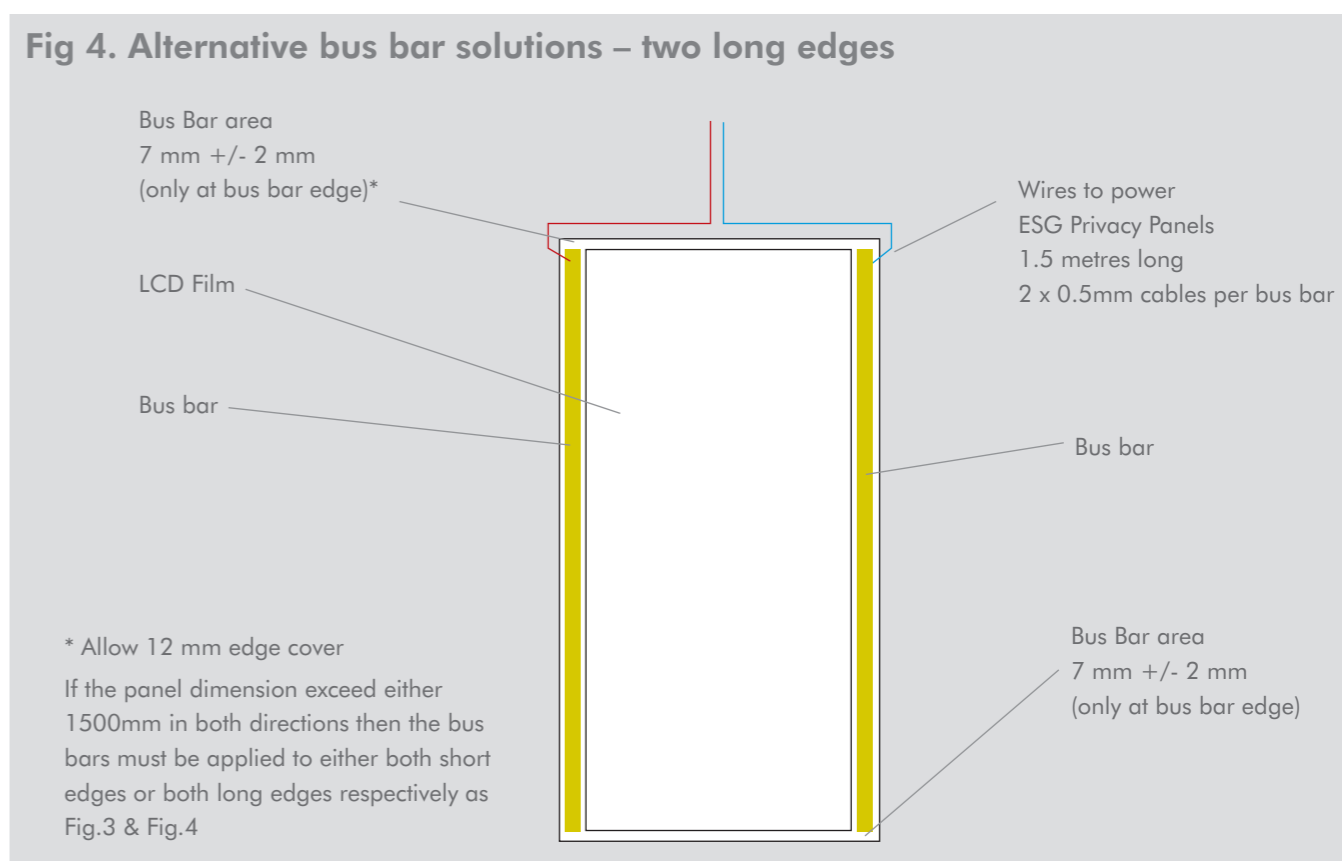

Fig 4. Alternative bus bar solutions – two long edges



Typical Wiring Diagrams

Figure One

Wireless Wall Switch / Remote Control Wiring Diagram

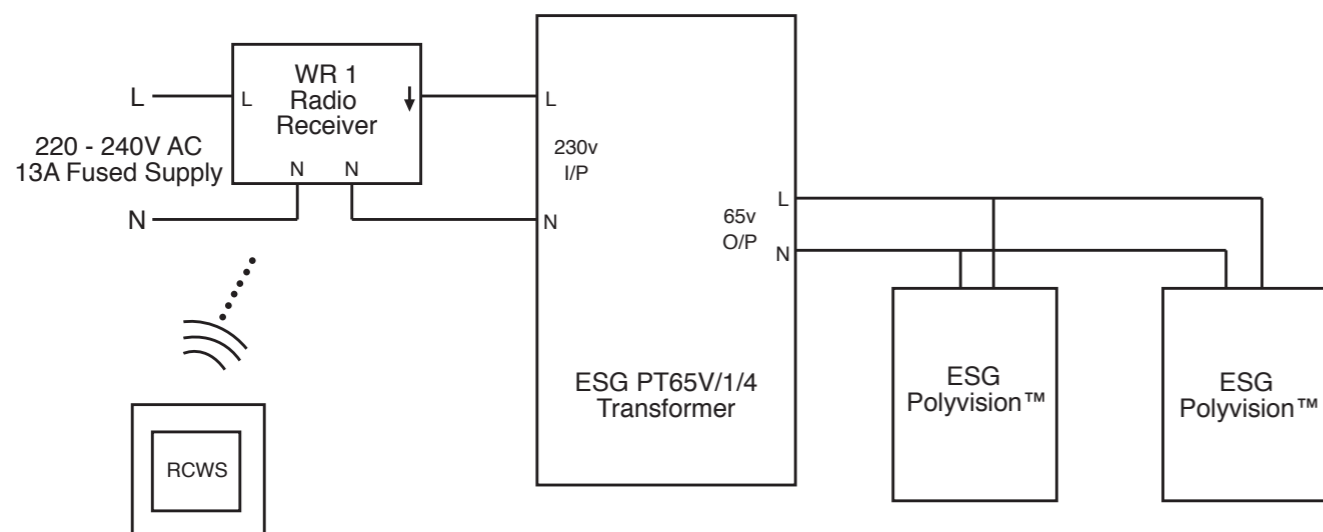

ESG2CH / Wireless Wall Switch / Remote controller

Please Note: The Power Transformer has a built in fuse and must be located in an accessible position

ESG PT65V/1/4 Power Transformer (230v AC to 65v AC) (130 x 90 x 76 mm) 1 required per switchable area up to 4m²

Figure Two

Standard Wiring Diagram

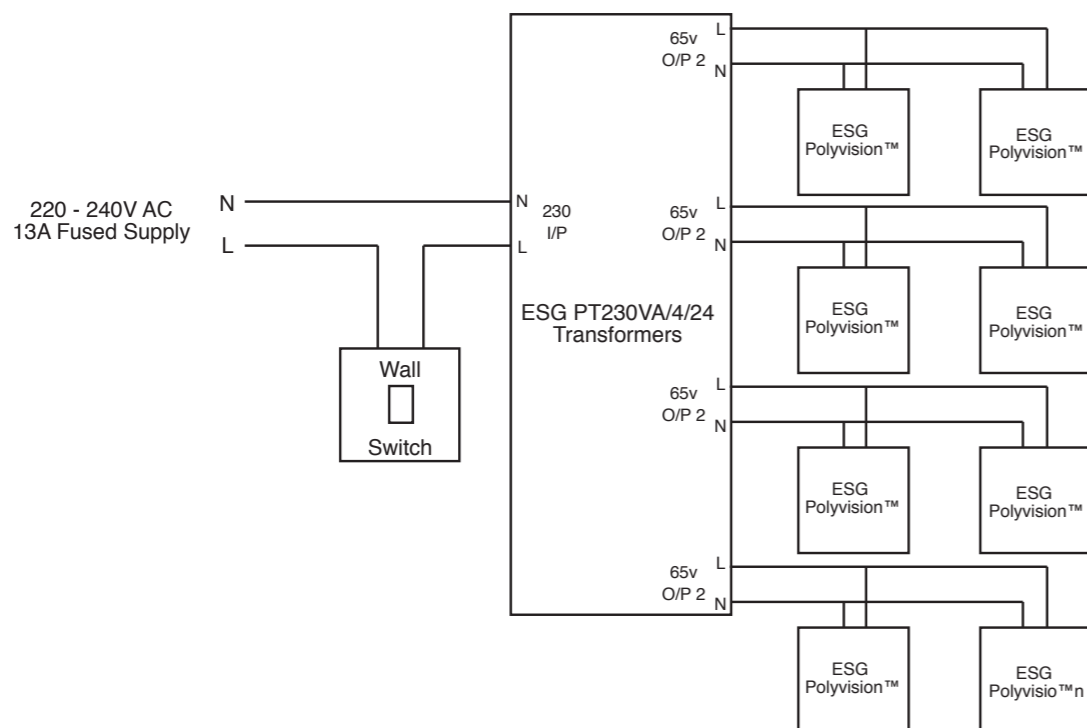

Please Note: The Power Transformer has a built in fuse and must be located in an accessible position

ESGPT 230VA/ 4 /24 Power Transformer (230v AC to 65 VAC) (260 x 130 x 130mm) 1 required per switchable area up to 4 x 4m²

Shipping & Receiving

Shipping

ESG Polyvision™ is delivered by ESG's own experienced logistics team throughout the UK.

Full crating and shipping service for export worldwide available.

All panels must be checked for damage when the panels are delivered and the delivery note marked accordingly as any claims for damage after the delivery driver has left will not be accepted. This includes delivery of both loose panels and those delivered on stillages. If the person receiving the panels marks the delivery note 'unchecked' or any variation on this term then they will still be deemed to have accepted the panels as undamaged and the panels will be chargeable. ESG will not be held responsible for damage if the person receiving the panels fails to inspect them.

Storage

- Glass edges frequently sustain damage due to careless handling at some point between manufacture and installation.
- Handle with care!
- If the glass is to be stored on the job site or in warehouse conditions, proper blocking and protection should be maintained at all times.
- As with other flat glass products, ESG Polyvision™ must be stored where the relative humidity is less than 80% to prevent the glass from staining.
- The glass temperature should be held nearly constant to prevent moisture condensation on the Panels. Storage temperature range is -20-70 °C.
- Panels should be tilted at 5° - 7° from vertical at all times using broad, sturdy uprights to support the weight of the glass.

"Unexpected" Breakage

"Unexplained" glass breakage may occur after all precautions have been taken. Such breakage is beyond the control of the manufacturer and therefore not warrantable. This includes but is not limited to the following items:

- thermal stress
- damage during sand blasting (if not performed by ESG)
- glazing system pressures
- damage during glazing
- handling and storage problems
- excessive wind loads
- objects and debris striking the glass
- damage by persons/objects at the construction site

Glazing - General Notes

Surface Conditions

- A.** Examine the areas and conditions under which work of this Section will be performed. Correct conditions detrimental to timely and proper completion of this work. Do not proceed until unsatisfactory conditions are corrected.
- B.** After preparation of the glazing system, clean glazing channels, stops and rabbets to receive the glazing materials, making free from obstructions and deleterious substances which might impair the work.
1. Remove protective coating which might fall in adhesion or interfere with bond of sealants.
 2. Comply with manufacturers' instructions for final wiping of surfaces immediately prior to application of primer and glazing compounds or tapes. USE ONLY NEUTRAL CURE SILICONES. DO NOT USE ACETIC SILICONES.

Installation

- A.** Inspect each piece of glass immediately prior to start of installation.
1. Do not install items which are improperly sized, have damaged edges, or are scratched, abraded, or deficient in any other manner.
 2. Do not remove labels where provided by the glass supplier from glass until so directed by the Architect.
 3. Adhere to all ESG installation instructions and installation drawings.
- B.** Locate sill setting blocks of standard width and thickness at quarter points of all glass lights unless otherwise recommended by manufacturer or supplier.
1. Use blocks of proper durometer, size and thickness to support the glass in accordance with the manufacturers' recommendations.
 2. Glass lap and edge clearances must be provided according to pertinent codes and standards of manufacturers

- C.** Set glass in a manner which produces the greatest possible degree of uniformity appearance.
1. Indicate clearly when install glass in dynamic frames such as operable windows or sliding doors.
 2. Glazing to the exterior and wet interior conditions must be wet-sealed and impervious to moisture with provisions to allow for weeping of condensation that may infiltrate of condensation in the system.
 3. Pressure glazing systems without positive positioning stops are not to be used with this glass.
 4. Glazier to place electrical connections properly to allow access by an electrician.
 5. Electrical connections must exit at the head condition of any framing system using ESG Polyvision™ panels in wet environment applications.
- D.** Cut and seal the joints of glazing gaskets in accordance with the manufacturers' recommendations, provide watertight and airtight seal at corners and other locations where joints are required.

Protection

Reapply protective film after glazing to avoid surface damage prior to commissioning.

Cleaning

Cleaning can be carried out much in the same way as normal glass by using a slightly damp cloth or professional glass cleaning product. Abrasive products should never be used, particularly when the surface to be cleaned has a reflective coating. ESG advise the use of a professional window cleaning service. Avoid excess moisture / chemical cleaning agents coming into contact with ESG Polyvision™ panel edges.

Setting/Glazing

ESG Polyvision™ panels may be oriented in any direction. The Flat Glass Marketing Association (FGMA) Glazing Guidelines are to be followed except as noted.

Glazing Methods

Interior Applications - Laminated ESG Polyvision™ panels

Dry Glazing: This is preferred interior glazing method.

Wet Glazing: If an elastomeric (non-acetic) sealant is used, it must be compatible with the panel polyvinyl butyral (PVB) interlayer.

Never use putty or glazing compound to glazing a ESG Polyvision™ panel.

Exterior Applications - Insulated Glass Units made with ESG Polyvision™

Wet Glazing: Pre-shimmed glazing tape and non-acetic sealants are required to create a seal impervious to moisture for all applications.

Butt-Joint Glazing:

ESG Polyvision™ panels can be butt-joint glazed in interior applications.

Structural Silicone Glazing

Insulate glass units manufactured with ESG Polyvision™ panels shall not be structurally silicone glazed.

Frame Design

- Standard frame edge clearance and face clearances may be used, EXCEPT edge bite must be 11 mm minimum and framing must have a hole of 6 mm diameter. To maintain a proper seal against the infiltration of water and air, adequate bite is required.
- Inadequate clearance for the edges can cause damage due to glass-to-frame contact.
- The industry standard for framing deflection must be adhered to. The deflection must not exceed either the length of the span divided by 175, or 18 mm, whichever is less. All expansion joints and anchors must be designed so that the glass framing does not incur a load due to structural movement.

Setting Blocks

- Glass larger than 0.5 square metres should be placed on two EPDM or neoprene setting blocks.
- These blocks should have a durometer hardness of 85±5.
- They should be centred at the bottom quarter points (i.e. equal distance).
- The blocks should be 1.5 mm narrower than the channel width.
- Lock-strip gasket systems also require setting blocks. Recommendations can be obtained from the gasket manufacturers.

Glass Protection

- Once the glass is installed, the architect, general contractor, or owner should provide for glass protection and cleaning.
- Weathering steel or alkaline materials may cause surface damage due to staining.
- Abrasive cleaners should never be used, particularly when the surface to be cleaned has a reflective coating.
- Windblown objects, welding sparks, or other material applied to the glass surface during construction may cause irreversible damage.

Trouble Shooting

Caution: ESG Polyvision™ operates at 65 VAC and 50 Hz. Higher voltage and frequency may cause permanent damages.

Troubleshooting and electrical service must be performed by a qualified electrician who has read and understood this document.

Switch the power ON. Verify that the panels turn clear. If one or more ESG Polyvision™ panels are not operating:

1. Check the circuit breaker to verify power. If there is no power from the circuit breaker, reset or replace the circuit breaker.
2. Check the wall switch to verify power. If there is no power from the wall switch check the connection or replace the wall switch.
3. Check input to the power supply of affected panels to verify power. If there is not input power to the transformer, check the wiring between the wall switch and the transformer.
4. Check output from the transformer to the affected panels to verify power. If there is no output power from the transformer, the fuse may have blown. Replace fuse with the same size and specifications which is available at electronic supply stores.

NOTES:

1. Use care when opening the transformer and allow a few minutes to cool down. Internal electronic parts may be very hot. This is normal.
2. Warning: Do not substitute a higher fuse rating! Fuse rating is critical to properly protect ESG Polyvision™ panels and the transformer.

Warranties

ESG warrants that ESG Polyvision™ panels should be free from defects for a period of five years from the date of invoice unless otherwise specified. Defects include loss of switching where the electrical system and supply are working correctly and/or de-lamination of the panel.

In the event of a breach of warranty for the reasons as above ESG will repair or replace the defective product. ESG will not accept any costs incurred by others which are associated with gaining access, removal, replacement, installation of panels or consequential loss claims of any kind.

The customer must advise ESG immediately they are aware a panel is defective and if installed they must leave the panel in situ. ESG will decide whether to inspect the installation on site or may ask to have defective product returned for repair or replacement.

ESG is not responsible for products which are damaged due to external events such as, but not limited to, natural disasters, incorrect silicone use, improper use, or maintenance or use of unauthorised parts.

To ensure safety and proper operation of ESG Polyvision™ and to avoid invalidating any warranty, the panels must be installed by a qualified electrician. ESG Polyvision™ should be delivered, handled, installed, protected, cleaned and used in compliance with all local legislation, regulations and codes of practice and in accordance with the requirements detailed in the ESG Polyvision™ Technical Binder and Operation & Maintenance Manual.

Haze – ESG Polyvision™ panels are not as optically clear as standard float glass. Some degree of haze will always appear due to the nature of the product make-up. As with all LCD switchable smart type privacy glass there will always be some degree of haze and this is not a reason for rejection or a refund.

A clear non switchable area of up to 5mm around the perimeter of ESG Polyvision™ Panels may be observed. This is a natural phenomenon and is not a fault in the product.

Our Quality Standards - Your Assurance

We are committed to giving customer satisfaction through service provision of the highest standard. This applies to all areas of our business and is central to our mission.

Our products are tested in house and by Europe's leading Independent, third-party certifiers and testers such as BRE, TNO, Technalia, Efectis, Wiltshire Ballistics and the British Standards Institute which distinguish our products and services from our competitors, and gives you, our customers, confidence about their performance.

ESG BALLISTIC

BS EN 1063:2000 Security Glazing – Testing and classification of resistance against bullet attack

QMS

BS EN ISO 9001 : 2008 – FM 511206

Audit Body – BSI (British Standards Institute)

Originally Registered – 8th January 2007

TOUGHENED GLASS

BSI Kite Mark Licence – KM 511207

Class 1 Toughened Glass - BS EN 12150 : 2000

(Glass in building. Thermally toughened soda lime silicate safety glass)

Impact Tested – BS EN 12600 : 2002

(Glass in building. Pendulum test. Impact test method and classification for flat glass)

HEAT STRENGTHENED GLASS

BSI Kite Mark Licence – KM 511207

Heat Strengthened Glass - BS EN 1863 : 2000

(Glass in building. Heat strengthened soda lime silicate glass).

Bending Strength Tested – BS EN 1288-3 : 2000

(Glass in building. Determination of the bending strength of glass – Part 3 – Test with specimens supported at two points – Four pointbending).

HEAT SOAKED GLASS

BSI Kite Mark Licence – KM 511207

Heatsoaked Glass – BS EN 14179 : 2005

(Glass in building. Heat-soaked thermally toughened soda lime silicate safety glass)

LAMINATED GLASS

BSI Kite Mark Licence – KM 511207

Laminated / Toughened Laminated Glass – BS EN 14449 : 2005 (Glass in building. Laminated glass and laminated safety glass)

Tested in accordance to – BS EN 12543-4 : 1998

(Glass in building. Laminated glass and laminated safety glass. Test methods for durability)

FIRE GLASS

BSI Kite Mark Licence – KM 511207 (For Impact – BS EN 12600:Class1, and Toughened glass - BS EN 12150 only.

Plus Fragmentation tested under BS EN 12150 by BSI)

Approved & Certified by CERTIFIRE for ESG Pyrotech E30 in timber and steel doors and screens, and ESG Pyrotech E30 and E60 within steel doors and screens – Certification Number: CF 628

SECURITY GLASS

BS EN 356 : 2000

(Glass in Building – Security glazing. Testing and classification of resistance against manual attack).

LPS 1270 Issue 1

(Requirements and testing procedures for the LPCB approval and listing of intruder resistant security glazing units).

